

QM-1 MKIII

(#33002)

Long-Distance Microscope

The QM-1 provides superb close-focus performance from 22 inches (560mm) to 66 inches (1520mm). It delivers the performance as the standard QM-1 for which Questar is famed. The QM-1 received an IR-100 award and was the first of a new series of long-distance microscope. The QM-1 is designed for accuracy and performance. It utilizes the Questar MKIII precision tube assembly design. There are no spacers, extenders, or diopters required. The QM-1 tube design allows for extended internal focus travel to accommodate this wide focus range. Focus is smooth and stable. The MKIII barrel design allows for integration of additional options such as motorized focus and future upgrade to SZ 83000 series. The improved boresight accuracy of this instrument provides greater accuracy in alignment applications. Equipped with a C-mount adapter, camera coupling set, target light and adapter along with a built-in beamsplitter, this unit is ready to attach to any CCD camera with a standard C-thread, and flexibility to be useful in virtually any situation. The working range and 20-1 variability in the field of view and remarkable depth of field, linearity and chromatic correction make this it an indispensable tool for any imaging application.

SPECIFICATIONS

Type	Maksutov Cassegrain Catadioptric		
Working range	560mm (22 inches) to 1520mm (66 inches)		
Clear Aperture	89mm		
Entrance Pupil	96mm Primary Mirror		
Relative Aperture/ Numerical Aperture	Working Distance	N.A.	f/#
	560mm (22 inch)	.0580	8.7
	700mm (27.5 inch)	.0511	10
	1020mm (40 inch)	.0385	12.9
	1400mm (55 inch)	.0288	16.8
Resolution	3 microns at 560mm (22 inches)		
Magnification	To 125 times visual, to 12 times at image plane		
Format	Variable depending on BFD, Auxiliary Lens & Imaging Device		
Back Focal Distance	Diffraction limited field 12mm, 18mm nearly diffraction limited 70mm (2.75 inch) minimum measured from back plate		

OPTICS

Corrector Lens	BK7, MgF ₂ coated, 89mm (3.5 inch) diameter
Primary Mirror	Pyrex, Aluminum coated, SiO overcoated, 96mm (3.8 inch) diameter
Secondary Mirror	Aluminum coated, R-I surface of corrector, 22mm (.87 inch) diameter
Baffling	Helix in central tube, black anti-reflection coated.

MECHANICAL

Barrel	Aluminum plate, machined & black anodized, modular fabricated construction
Lens Cell	Hollow bar, machined & black anodized, precision turned mounting surface & pilot flange
Focus Mechanism	Corrector focus 6 point bearing structure, 6 precision pressed & loaded bearing & matched stainless steel slide rods, direct drive lead screw focuser & matching anti-backlash ball nut & bronze support bearings.
Mirror Mounting	Fixed position, 3" diameter stainless steel mounting plate, matched & fitted to barrel assembly, mirror thimble precision thread to match plate
Knobs	Aluminum
Hardware	Stainless steel

Specifications Subject to change without notice

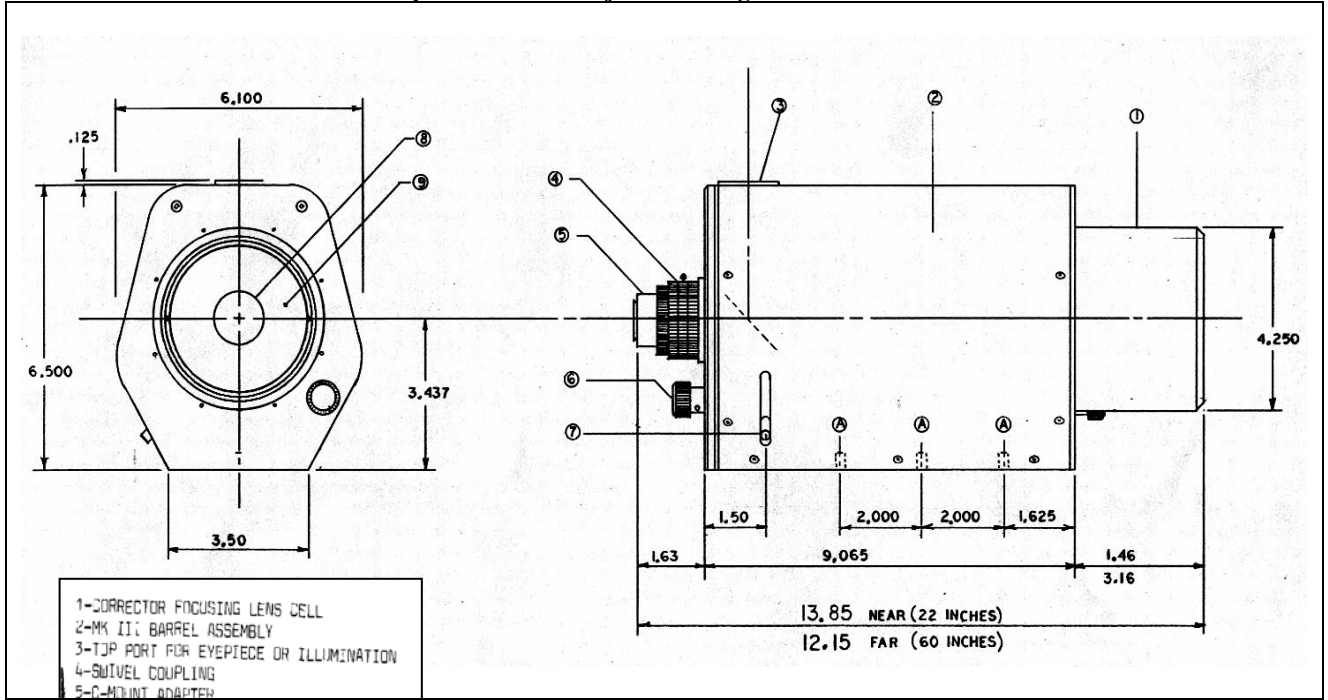

FOV Chart for the QM-1

QM-1 Field of View (2/3" CCD)

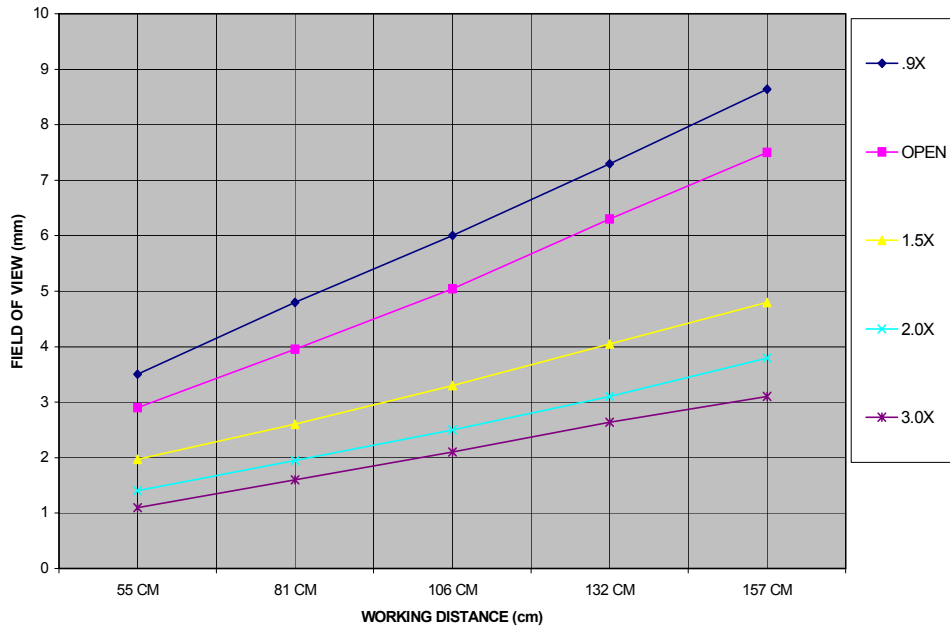

Questar Corporation
 6204 Ingham Road
 New Hope, PA 18938
 USA

Telephone
 Fax
 Email
 Web

215-862-5277 or 800-247-9607
 215-862-0512
questar@QuestarCorporation.com
www.QuestarCorporation.com